

**ALL-
NEW**

MAGNETIC CAM LOCK

FEATURES

- ✓ Keys cannot be copied
- ✓ Lock cannot be picked/bumped
- ✓ Resistant to glue, dirt, and other contaminants
- ✓ Retrofit from any standard cam lock
- ✓ Over 1,500 magnetic locking combinations
- ✓ Discreet
- ✓ No Keyway
- ✓ Water-tight construction



APPLICATIONS

HOME



OFFICE



INSTITUTIONAL



INDUSTRIAL



TECH SPECS

ITEM #	Description
81300	1-3/8" Magnetic Cam Lock
81100	1-1/8" Magnetic Cam Lock
87800	7/8" Magnetic Cam Lock
85800	5/8" Magnetic Cam Lock
MK3W01	Magnetic Key for Cam Lock
KT3W01-20	Keying Kit (20 Keys)

- Standard Finish: Nickel
- Cam Rotation to be specified
- Keyed alike or different
- Inquire for other finishes
- Inset-offset cams available
- 2 keys included

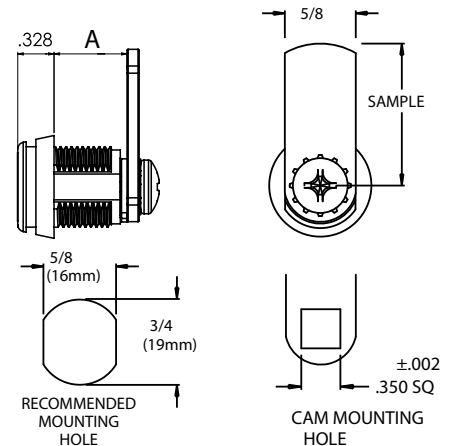

5795 de Gaspé | Montréal, QC | H2S 2X3
 Tél: 514.273.0451 | 1.800.567.0451
 Fax: 514.273.2928
www.capitolindustries.com

CI CAPITOL
INDUSTRIES INC.

**NOUVEAU
PRODUIT**

SERRURE À CAME MAGNÉTIQUE



CARACTÉRISTIQUES

- ✓ Les clés ne peuvent pas être copiées
- ✓ Serrure ne peut pas être crochetée
- ✓ Résiste la colle, poussière, autres contaminants
- ✓ Retrofit de toute serrure à came standard
- ✓ Plus de 1,500 combinaisons magnétiques
- ✓ Discret
- ✓ Aucun trou de clé
- ✓ Construction étanche

APPLICATIONS

RÉSIDENTIEL



BUREAU



INSTITUTIONNEL



INDUSTRIEL



SPÉCIFICATIONS TECHNIQUES

ITEM #	Description
81300	1-3/8" Serrure à came magnétique
81100	1-1/8" Serrure à came magnétique
87800	7/8" Serrure à came magnétique
85800	5/8" Serrure à came magnétique
MK3W01	Clé pour serrure à came magnétique
KT3W01-20	Kit de cléage (20 clés)

- Fini Standard: Nickel
- Rotation de came à préciser
- Cléage identique ou différent
- Autres finis disponibles
- Cames décalées disponibles
- Fourni avec 2 clés

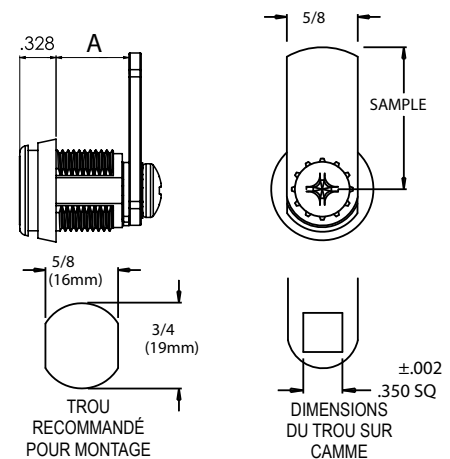

5795 de Gaspé | Montréal, QC | H2S 2X3
Tél: 514.273.0451 | 1.800.567.0451
Fax: 514.273.2928
www.capitolindustries.com

**CAPITOL
INDUSTRIES INC.**